

F3 remote indication



F3 remote indication for flush-mounting



F3 remote indication

The F3 remote indication ensures display of the most important installation functions via battery supply also with mains power failure. Blocking of emergency lighting operation is possible via a key switch during idle operation times. Blocking of emergency operation does not affect battery maintenance charging. Differential loop monitoring leads to operational readiness of the system with short circuits or wirebreak detection. LED displays: system readiness, source for safety services, failure. As such the F3 remote indication fulfills the requirement that remote switching is only permissible when operation by unauthorized persons is not possible.

Connection terminals wall surface-mounting	2.5 mm ² rigid and flexible
Dimensions mm (H x W x D)	160 x 80 x 55
Connection terminals for flush-mounting	1.5 mm ² rigid or 1 mm ² flexible
Dimensions mm (H x W x D)	80 x 80 x 55
Colour enclosure	sim. RAL 7035 Light grey

2

Ordering details

Type	Scope of supply	Order No.
F3 remote indication	Module surface-mounting	40071338497
F3 remote indication recessed	Performance for installation in the flush-mounted switch or empty space box acc. to DIN VDE 0606	40071347490

Remote switch

Control loop for blocking the installation during factory shutdowns with differential loop monitoring for short-circuit and open circuit detection.

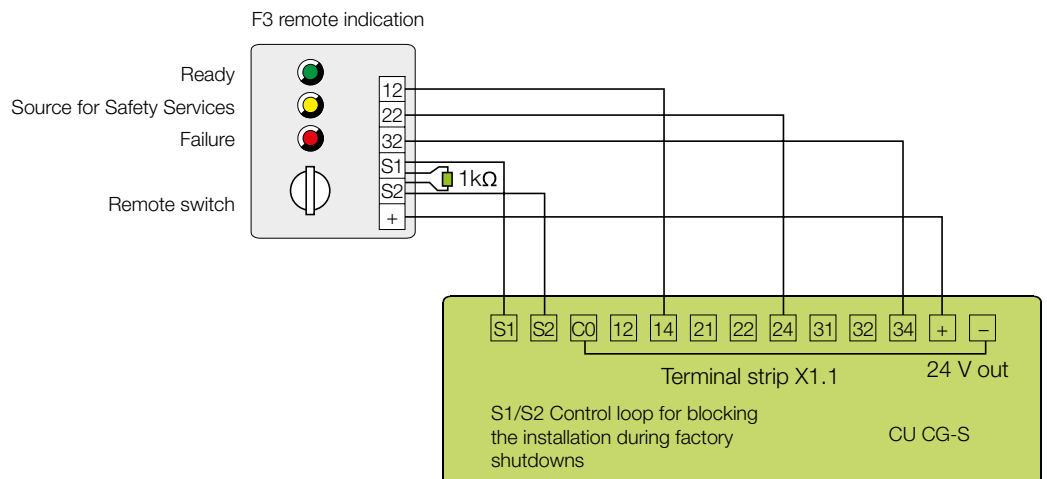

Differential monitoring:

A short-circuit or open circuit causes the system to be enabled.

F3 switch closed:

System ready

F3 switch open (1 k Ω):

System blocked